

## PRO-36 | COMPACT DRILLING MACHINE

The PRO-36 makes holes up to 36 mm in diameter by using annular cutters. The machine can also drill holes up to 12 mm in diameter by means of twist drill bits with Weldon shank 19mm (3/4").

Compact design and excellent ratio weight/power make this mag drill a very popular choice for customers.



### Features & benefits:

- Dual bars guide system ensures extraordinary stiffness and adjustment free operation
- Compact size and ultra-lightweight – ideal for site work
- Rugged one piece slide and gear box for extra stability
- Purpose designed motor with heavy duty gear box
- Maintenance-friendly design makes it easy to use
- Magnetic Field Shape Control (MFSC) provides maximum holding power on thin materials
- Magnetic Power Adhesion Control (MPAC) detects adhesive force of electromagnetic base and protects both the machine and the operator from work on too thin work piece

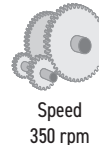
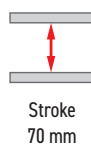
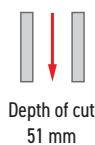



Max  
Ø 36 mm  
(1 7/16")



Max  
Ø 40 mm  
(1 9/16")



Max  
Ø 12 mm  
(1/2")

#### PRO-36 TECHNICAL SPECIFICATION

Motor Speed (under load)	350 rpm
Power	1020 W
Weight	10 kg
Max milling capacity	36 mm (1 7/16")
Max drilling capacity	12 mm (1/2")
Max countersinking	40 mm (1 9/16")
Stroke	70 mm (2 3/4")
Max depth of cut	51 mm (2")
Voltage	1~ 220-240 V, 50-60 Hz 1~ 110-120 V, 50-60 Hz
MPAC (Magnetic Power Adhesion Control)	yes
MFSC (Magnetic Field Shape Control)	yes
Magnetic clamping force (surface with the thickness of 25 mm and roughness Ra = 1.25)	917 kgf (9000 N)
Magnet Base Dimensions	80 x 161 x 36,5 [mm] 3-1/8 x 6-5/16 x 1-7/16 ["]
Min. Workpiece Thickness	6 mm (1/4")
Tool holder	19 mm (3/4") Weldon
Product Code 230V/50Hz	WRT-0440-10-20-00-4
Product Code 115V/60Hz	WRT-0440-10-10-00-4

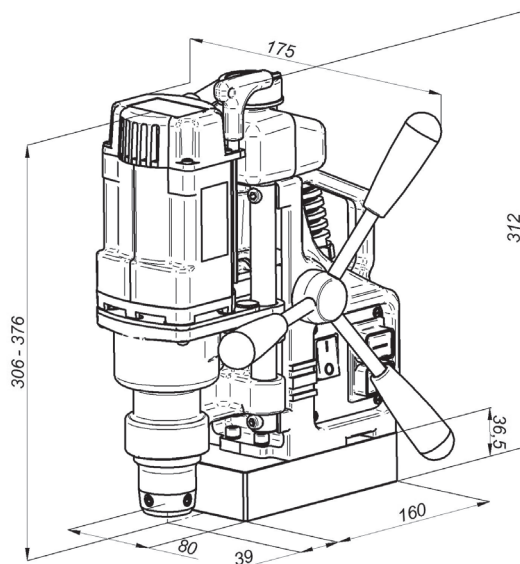

#### Standard shipping set:

- Magnetic Base Drilling Machine
- Plastic Box
- Swarf Shield/Cutter Guard
- Coolant Bottle Assembly
- Safety Chain with Snap Hook
- Allen wrench hex s=4
- Operator's Manual
- Standard shipping weight - 16,7 kg (36 lbs)

#### Selected additional accessories:

- UKL-0440-16-00-00-0 Coolant System 2l
- PDS-0587-10-00-00-0 Vacuum pad
- ZSP-0587-11-00-00-0 Compressed air ejector
- PDS-0110-10-00-01-0 Pipe attachment DMP 250 for pipes with diameters of 80-250 mm (3-10")



Pipe attachment DMP 250



Coolant System 2l



Vacuum pad



Compressed air ejector

All information is subject to change without notice. 25.02



Your local dealer:



Vertrauen Sie auf bald 80 Jahre Erfahrung!

Die Firma **Hesse + Co** wurde 1947 als Hersteller von Blechbearbeitungsmaschinen gegründet. Seit 1980 sind wir auf den Handel mit neuen sowie gebrauchten Blechbearbeitungs- und Werkzeugmaschinen spezialisiert.

Wir haben ständig etwa 300 Maschinen in unserer 2.000 m<sup>2</sup> großen Ausstellungshalle, die nur 20 Minuten vom internationalen Flughafen Wien entfernt ist.

Trust in nearly 80 years of experience!

*Hesse + Co was established in 1947 as a manufacturer of sheet metal working machines. Since 1980 we are specialized in dealing with new and second hand sheet metal processing machines and machine tools. We always have approximately 300 machines available in our 2.000 m<sup>2</sup> showroom, which is located only 20 minutes from the Vienna International Airport, waiting for your inspection.*

[www.hesse-maschinen.com](http://www.hesse-maschinen.com)

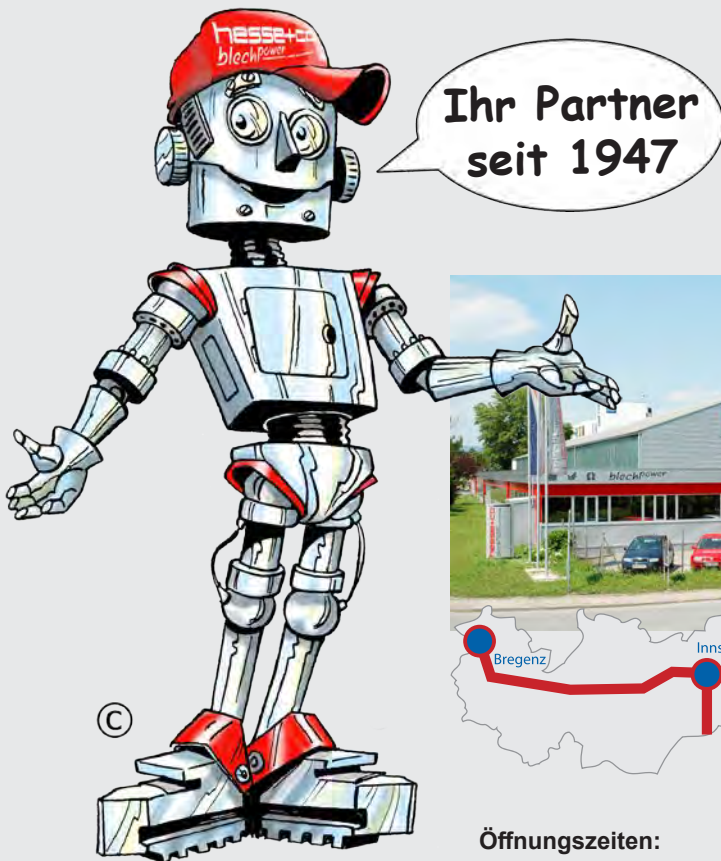

**Öffnungszeiten:**

Mo - Do 7:45 - 16:30 Uhr  
Fr 7:45 - 13:15 Uhr

**Hesse + Co Maschinenfabrik GmbH**  
Industriezentrum NÖ-Süd  
Straße 4 - Objekt 8  
A-2351 Wiener Neudorf  
AUSTRIA

**hesse** **hesse+co**  
*blechpower*  
maschinen und werkzeuge

Tel.: +43/2236/638 70-0  
[office@hesse-maschinen.com](mailto:office@hesse-maschinen.com)  
[www.hesse-maschinen.com](http://www.hesse-maschinen.com)

Technische Änderungen, Irrtum und Druckfehler vorbehalten.  
Gültig bis auf Widerruf.