

2023



LFSS



HAKKIMIZDA

Türkiye'nin en büyük sanayi şehirlerinden Bursa'da kurulan LFSS ŞAHİN MAKİNA geçmişten bugüne taşıdığı tecrübesi ve disiplinli çalışması ile bir çok sektörün gereksinimi olan Hidrolik Pres, Giyotin Makas, Köşe Kesme, Profil & Boru Kıvrırma Makinaları ve metal işleme sektörünün ihtiyaçlarına yönelik olarak diğer sac işleme makinelerini üretmektedir. Üretiminin %80'ini yurtdışı pazarlarına yapan firmamız, Avrupa başta olmak üzere Amerika, Afrika, Uzakdoğu ve Ortadoğu ülkelerine ihracatını her geçen gün arttırmaktadır.

Hedefimiz; devamlı gelişen makina endüstrisinde yatırımlarımızı büyüterek marka değerimizi sürekli daha ileriye taşımaktır.

ABOUT US

LFSS ŞAHİN MAKİNA has been established in Bursa, which is one of the biggest industrial city in Turkey, is producing the requirement machines of many sectors such as Hydraulic presses, Guillotine shears, Corner Notchers, Profile and pipe bending machines related sheet metal working machinery along with its disciplined work and experience which comes through today. Our company exports the %80 of its production to America, Africa, Far East, Middle East and mainly to Europe and developing itself by increasing the export level by each passing day.

Our target is to increase the investments in the developing sector in order to provide constant growth in our brand.

85

ÜLKEYE
İHRACAT
EXPORT
COUNTRIES



WHAT IS YOUR NEED?



HİDROLİK PRES

HYDRAULIC
PRESS



GİYOTİN MAKAS

GUILLOTINE
SHEAR



KÖŞE KESME

CORNER
NOTCHER

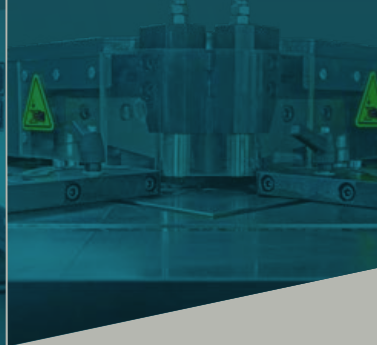

PROFİL & BORU KIVIRMA

PROFILE
& PIPE
BENDING

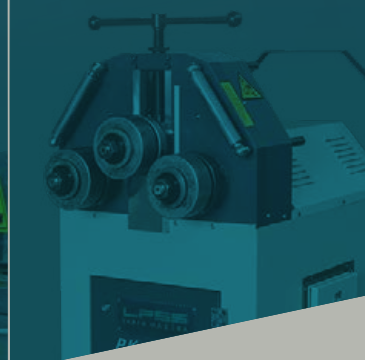

İÇİNDEKİLER

INDEX

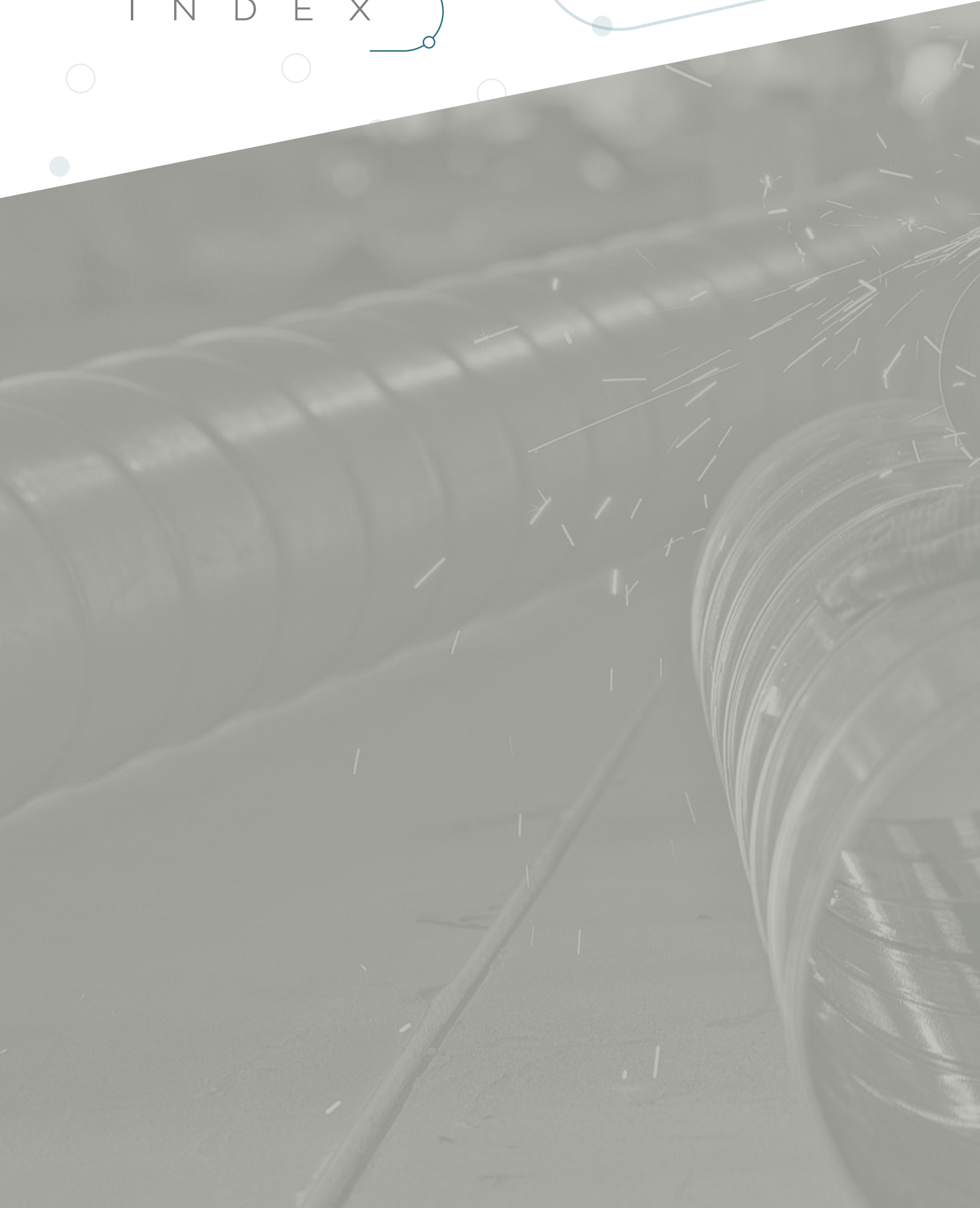





HİDROLİK PRES
HYDRAULIC PRESS

Web Sitesine Git
Go To The Web Site

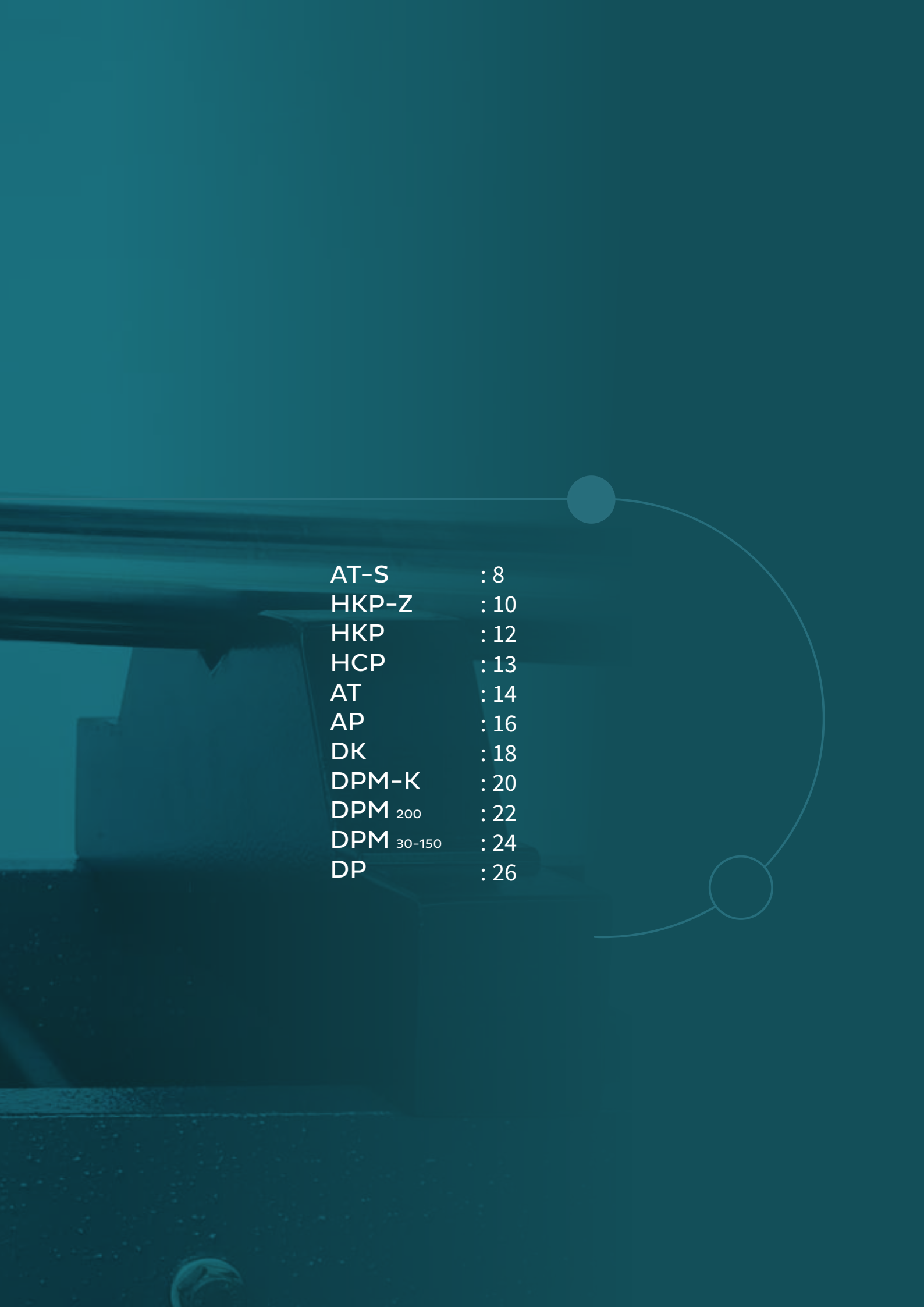

AT-S	: 8
HKP-Z	: 10
HKP	: 12
HCP	: 13
AT	: 14
AP	: 16
DK	: 18
DPM-K	: 20
DPM ₂₀₀	: 22
DPM ₃₀₋₁₅₀	: 24
DP	: 26



H TİPİ PRES
H-FRAME PRESS

AT-S

100 Ton
150 Ton



Manometre
Manometer



Basınç Ayar Valfi
Pressure Adjustment Valve



Acil Durum Kolu
Emergency Stop Switch

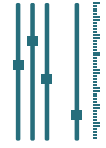

Ayarlanabilir Kurs
Adjustable Stroke



Çift El Kontrol Paneli
Two Hand Control

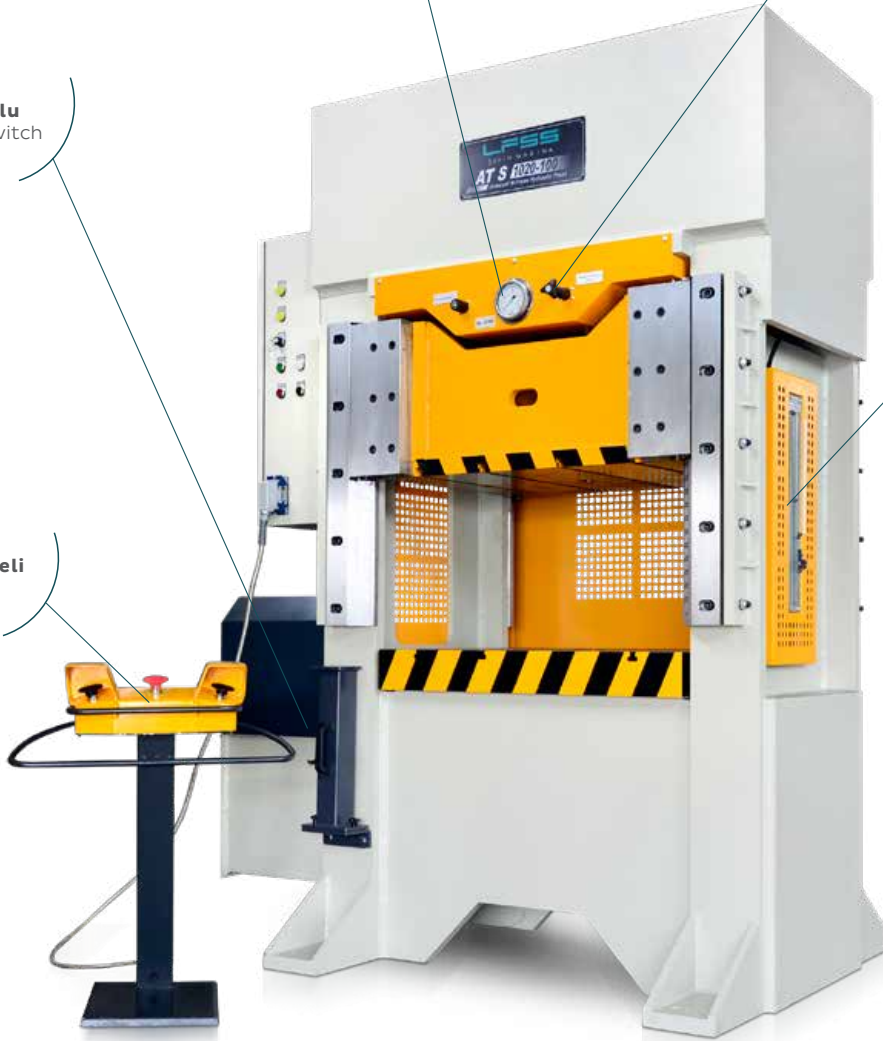

GENEL ÖZELLİKLER

- Yüksek kapasiteli H Tipi hidrolik pres. (1020 mm tek pistonlu, 1520 mm çift pistonlu)
- Çelik konstrüksiyon kaynaklı gövde
- Üst tabla yanarlardan kızaklı rijitlenmiştir.
- T-Kanallı alt ve üst tabla
- Basınç göstergesi (manometre)
- Arka ve yanlarda güvenlik için koruma sacları
- Kurs; kademesiz olarak ayarlanabilir
- Basınç; kademesiz olarak ayarlanabilir
- Çift el ile kontrol

GENERAL FEATURES

- High capacity H-frame press (1020 single, 1520 double piston)
- Steel construction welded frame
- Ram table with prismatic maintenance free slide system
- T-Slot ram and bottom table
- Manometer
- Sheet cover both sides and rear for protection
- Stepless stroke adjustment
- Pressure, stepless adjustment
- Two hand control

OPSİYONEL

OPTIONAL



Derin Sıvama İçin Alt Pot
Bottom Cushion For Deep Drawing



Çift El Kumanda Kontrolü ve Ayak Pedalı
Two Hand Control and Foot Pedal



Işık Perdesi
Light Curtain



Arka Koruma
Sheet Cover for Protection

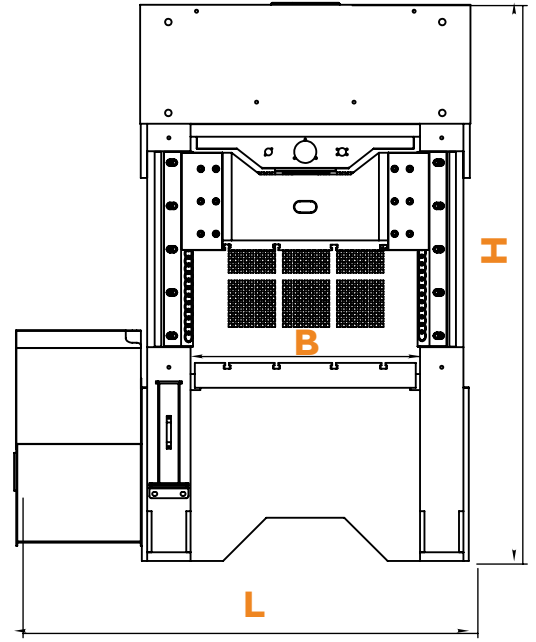
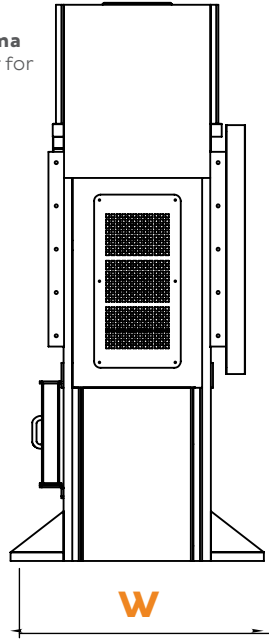

AT-S

			1020-100	1520-100	1020-150	1520-150
Basma Gücü	Press Power	kN	1000	1000	1500	1500
Maks. Çalışma Basıncı	Max. Working Pressure	bar	263	197	244	240
Kurs	Stroke	mm	300	300	300	300
Alt-Üst Tabla Aralığı	Top-Bottom Table Distance	mm	500	500	500	500
İniş Hızı	Advance Speed	mm/sec	8	9	8	9
İş Hızı	Working Speed	mm/sec	4,5	5	4,5	5
Geri Dönüş Hızı	Return Speed	mm/sec	9,5	10	9,5	10
Üst Tabla Ölçüsü	Ram Dimension	mm	700x1020	700x1520	700x1020	700x1520
Alt Tabla Ölçüsü	Bottom Table Dimension	mm	700x1020	700x1520	700x1020	700x1520
Alt Tabla Merkez Deliği	Bottom Table Hole Diameter	mm	100	100	100	100
Motor Gücü	Motor Power	kW	7,5	7,5	11	11
B Çalışma Aralığı	B Working Area	mm	1020	1520	1020	1520
L Uzunluk	L Length	mm	2150	2650	2150	2650
W Genişlik	W Width	mm	1170	1170	1170	1170
H Yükseklik	H Height	mm	2600	2600	2600	2600
Ağırlık	Weight	kg	6000	7800	6500	8000



ÇİFT TESİRLİ HİDROLİK C TİPİ DERİN SIVAMA PRESİ

HYDRAULIC C-FRAME DEEP DRAWING
DOUBLE ACTION PRESS

HKP - Z

30 Ton
60 Ton
100 Ton
150 Ton



Manometre
Manometer



Işık Perdesi
Light Curtain



Ayarlanabilir Kurs
Adjustable Stroke

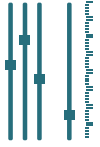

Alt Pot
Ayarlanabilir Kurs
Cushion Adjustable
Stroke



Basınç Ayar Valfi
Pressure Adjustment
Valve



Çift El Kontrol Paneli
Two Hand Control

GENEL ÖZELLİKLER

- Çelik konstrüksiyon kaynaklı gövde
- Çift el kontrol
- PLC'li elektrik donanımı
- Kademesiz ayarlı alt pot
- Üst tabla yanlardan kızaklı rijitlenmiştir.

GENERAL FEATURES

- Steel welded construction
- Two-hand control
- PLC control
- Cushions stroke adjustable
- Ram table with prismatic maintenance free slide system

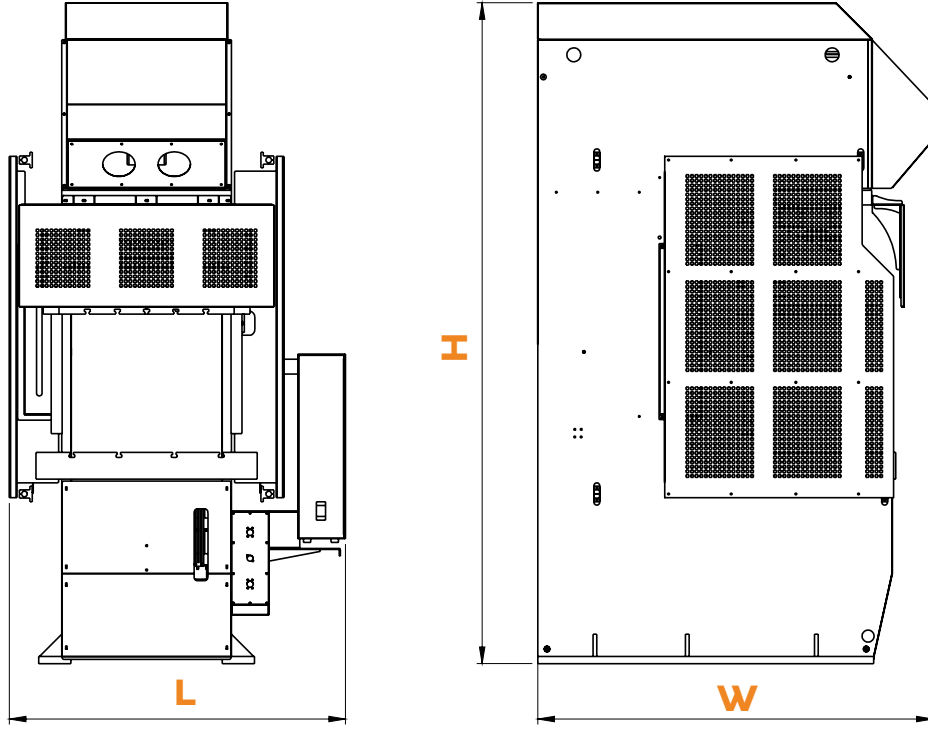

HKP-Z

			30	60	100	150
Basma Gücü	Press Power	kN	300	600	1000	1500
Kurs	Stroke	mm	300	350	500	500
Maks. Çalışma Basıncı	Max.Working Pressure	bar	160	170	240	254
İniş Hızı	Advance Speed	mm/sec	100	100	100	100
İş Hızı (Maks. Basınçta)	Working Speed (At Max. Pressure)	mm/sec	18	10	8.5	5.5
Geri Dönüş Hızı	Return Speed	mm/sec	165	165	165	165
Çene Açıklığı	Throat Depth	mm	550	600	750	750
Alt Tabla Ölçüsü	Die Table Dimension	mm	600x900	600x1000	700x1100	750x1200
Üst Tabla Ölçüsü	Ram Table Dimension	mm	500x800	550x850	600x900	650x950
Merkez Uzaklığı	Center Distance	mm	250	240	300	320
Mapa Deliği	Hole on Die Table	mm	80	100	120	120
Alt Pot Gücü	Cushion Power	kN	120	240	300	400
Alt Pot Kursu	Cushion Stroke	mm	150	150	200	200
Alt Pot Çalışma Basıncı	Cushion pressure	bar	130	156	170	160
Alt Pot Geri Dönüş Hızı	Return Speed of Cushion	mm/sec	100	65	52	40
Alt Pot Tablası	Cushion Table	mm	500x600	470x650	700x400	720x540
Motor Gücü	Motor Power	kW	11	11	11	11
L Uzunluk	L Length	mm	1950	1950	2100	2200
W Genişlik	W Width	mm	1900	1900	1900	2200
H Yükseklik	H Height	mm	2800	2850	3350	3650
Ağırlık	Weight	kg	4850	5350	7300	9500



HİDROLİK C-TİPİ HIZLI DERİN SIVAMA PRESİ HYDRAULIC C-FRAME DEEP DRAWING FAST VERSION PRESS

HKP

30 Ton
60 Ton
100 Ton
150 Ton



Manometre
Manometer



Basınç Ayar Valfi
Pressure Adjustment
Valve

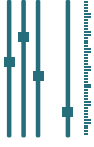

Ayarlanabilir Kurs
Adjustable Stroke



Işık Perdesi
Light Curtain



GENEL ÖZELLİKLER

- Çelik konstrüksiyon kaynaklı gövde
- Çift el kontrol
- PLC'li elektrik donanımı
- Üst tabla yanlardan kızaklı rijitlenmiştir.

GENERAL FEATURES

- Steel welded construction
- Two-hand control
- PLC control
- Ram table with prismatic maintenance free slide system



Çift El Kontrol Paneli
Two Hand Control



HKP

			30	60	100	150
Basma Gücü	Press Power	kN	300	600	1000	1500
Kurs	Stroke	mm	200	250	300	300
Maks. Çalışma Basıncı	Max.Working Pressure	bar	160	170	240	254
İniş Hızı	Advance Speed	mm/sec	100	100	100	100
İş Hızı (Maks. Basınçta)	Working Speed (At Max. Pressure)	mm/sec	18	10	8.5	5.5
Geri Dönüş Hızı	Return Speed	mm/sec	165	165	165	165
Çene Açıklığı	Throat Depth	mm	450	500	550	550
Alt Tabla Ölçüsü	Die Table Dimension	mm	600x1000	600x1000	700x1100	750 x1200
Üst Tabla Ölçüsü	Ram Table Dimension	mm	500x800	550 x 850	600 x 900	650 x 950
Merkez Uzaklığı	Center Distance	mm	250	240	300	320
Mapa Deliği	Hole on Die Table	mm	80	100	120	120
Motor Gücü	Motor Power	kW	11	11	11	11
L Uzunluk	L Length	mm	1950	1950	2100	2200
W Genişlik	W Width	mm	1900	1900	2050	2200
H Yükseklik	H Height	mm	2650	2750	3050	3250
Ağırlık	Weight	kg	4700	5300	6500	8200



C TİPİ PRES C-FRAME PRESS

HCP

30 Ton
60 Ton
100 Ton
150 Ton



Manometre
Manometer



Basınç Ayar Valfi
Pressure Adjustment Valve

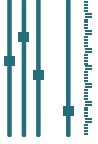

Ayarlanabilir Kurs
Adjustable Stroke

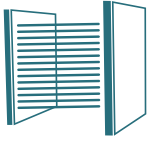

Işık Perdesi
Light Curtain



- Çelik konstrüksiyon kaynaklı gövde
- Çift el kontrol
- 4 Kılavuz yataklı ana piston

GENERAL FEATURES

- Steel welded construction
- Two-hand control
- Top ram is equipped with 4 guide pistons



Çift El Kontrol Paneli
Two Hand Control



HCP

			30	60	100	150
Basma Gücü	Press Power	kN	300	600	1000	1500
Kurs	Stroke	mm	200	250	300	300
Maks. Çalışma Basıncı	Max. Working Pressure	bar	244	236	263	244
İniş Hızı	Advance Speed	mm/sec	54	26	17,5	10
İş Hızı (Maks. Basıncıta)	Working Speed (At Max. Pressure)	mm/sec	18	8.5	5.5	3.5
Gerİ Dönüş Hızı	Return Speed	mm/sec	90	47	37	22
Çene Açıklığı	Throat Depth	mm	400	450	550	550
Alt Tabla Ölçüsü	Bottom Table Dimension	mm	450x700	500x750	600x1100	700x1100
Üst Tabla Ölçüsü	Ram Dimension	mm	380x500	430x500	420x680	500x750
Merkez Uzaklığı	Center Distance	mm	200	250	240	300
Mapa Deliği	Hole on Die Table	Ømm	80	100	120	120
Motor Gücü	Motor Power	kW	7,5	7,5	7,5	7,5
Yağ Pompa Kapasitesi	Pump-Flow	lt/min	40	40	40	40
Hidrolik Tank	Oil Tank	lt	150	200	300	340
L Uzunluk	L Length	mm	1200	1250	1500	1700
W Genişlik	W Width	mm	1650	1760	1810	2200
H Yükseklik	H Height	mm	2150	2250	2650	2700
Ağırlık	Weight	kg	2950	4000	5400	7700



ÜNİVERSAL T-KANALLI HİDROLİK PRES UNIVERSAL T-SLOT HYDRAULIC PRESS

AT

1020/1520-150 Ton
1020/1520-100 Ton



Manometre
Manometer



Basınç Ayar Valfi
Pressure Adjustment Valve



Çift El
Kontrol Paneli
Two Hand Control

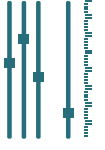

Ayarlanabilir Kurs
Adjustable Stroke

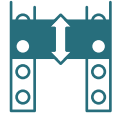

Ayarlanabilir
Alt Tabla
Adjustable
Bottom Table

GENEL ÖZELLİKLER

- Kalıp bağlamak için T-Kanallı alt ve üst tablalar
- Çelik konstrüksiyon kaynaklı gövde
- Yanlarda iki ilave kılavuz vazifesi gören miller
- Ayarlanabilir alt tabla
- Tabla indirme-kaldırma tertibatı
- İstenilen basınçta çalışma imkanı
- Basınç göstergesi (manometre)
- Kademesiz olarak ayarlanabilir kurs (switch)
- Çift el ile kontrol

GENERAL FEATURES

- T-Slot top-and bottom table
- Steel construction welded frame
- Two guide piston both side
- Adjustable bottom table
- Table up-down movement attachment
- Adjustable pressure valve
- Manometer
- Stepless stroke adjustment
- Two hand control

OPSIYONEL

OPTIONAL



Çift El Kumanda Kontrolü ve Ayak Pedali
Two Hand Control and Foot Pedal



Abkant Bıçak Tutma Aparatı
Press Brake Tooling



İsteğe Göre Özel T-Kanallı Tablalar
Specific T-Slot Tables

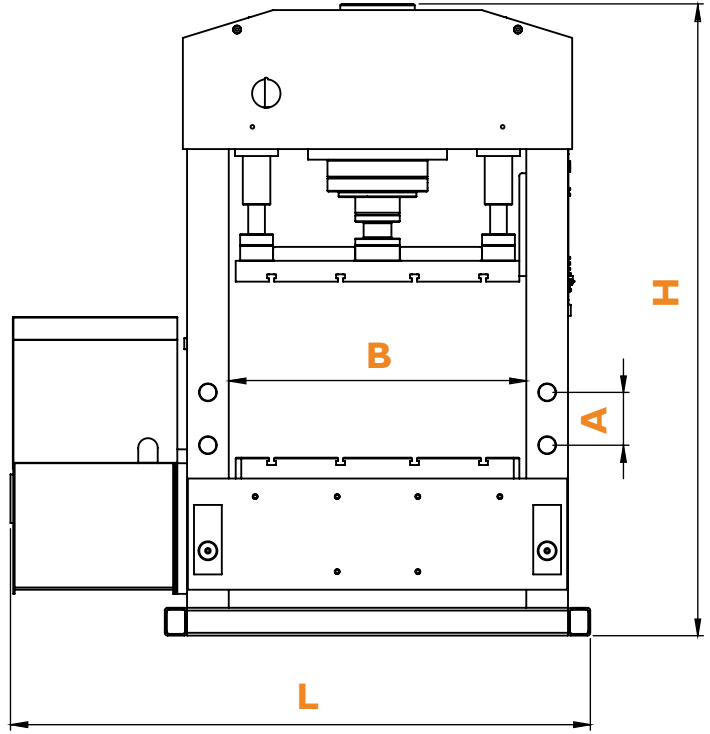
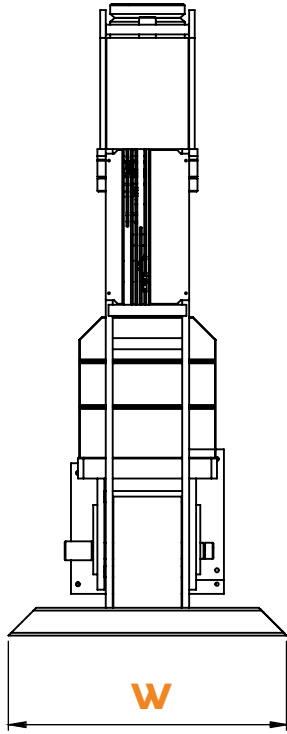

AT

			1020-100	1520-100	1020-150	1520-150
Basma Gücü	Press Power	kN	1000	1000	1500	1500
Maks. Çalışma Basıncı	Max. Working Pressure	bar	263	263	244	244
Kurs	Stroke	mm	300	300	300	300
Alt-Üst Tabla Aralığı	Top-Bottom Table Distance	mm	680	680	610	610
İniş Hızı	Advance Speed	mm/sec	8	8	9	9
İş Hızı	Working Speed	mm/sec	5	5	5	5
Geri Dönüş Hızı	Return Speed	mm/sec	10	10	10	10
Alt Tabla Ölçüsü	Bottom Table Dimension	mm	500x1020	500x1520	600x1020	600x1520
Alt Tabla Merkez Deliği	Bottom Table Hole Diameter	mm	100	100	100	100
Motor Gücü	Motor Power	kW	7,5	7,5	11	11
A Delik Mesafesi	A Hole Distance	mm	190	190	190	190
B Çalışma Aralığı	B Working Area	mm	1020	1520	1020	1520
L Uzunluk	L Length	mm	2110	2610	2110	2610
W Genişlik	W Width	mm	1000	1000	1000	1000
H Yükseklik	H Height	mm	2350	2350	2430	2430
Ağırlık	Weight	kg	1985	2365	2600	3200



ABKANT TİPİ PRESLER GARAGE TYPE PRESS BRAKES

AP

1020/1520-150 Ton
1020/1520-100 Ton



Manometre
Manometer



Basınç Ayar Valfi
Pressure Adjustment Valve



Çift El Kontrol Paneli
Two Hand Control

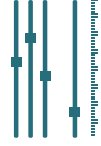

Ayarlanabilir Kurs
Adjustable Stroke



Sertleştirilmiş Bıçak
Hardened Blade



5 Ağızlı Prizma
5 Face Prism

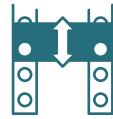

Ayarlanabilir Alt Tabla
Adjustable Bottom Table

GENEL ÖZELLİKLER

- Sertleştirilmiş abkant bıçakları
- Çelik konstrüksiyon kaynaklı gövde
- 5 Ağızlı prizma
- T-Kanallı alt tabla
- Kademesiz olarak ayarlanabilir kurs (switch)
- Basınç göstergesi (manometre)
- Ayarlanabilir alt tablalar
- Tabla indirme-kaldırma tertibatı
- İstenilen basınçta çalışma imkanı
- Büyük sacları kıvrım için büyük geçiş alanı
- Çift el ile kontrol

GENERAL FEATURES

- Hardened blades
- Steel construction welded frame
- 5-face prism
- Bottom table with T-Slot
- Stepless stroke adjustment
- Manometer
- Adjustable bottom table
- Table up-down movement attachment
- Adjustable pressure valve
- Adequate workspace for large sheets
- Two hand control

OPSIYONEL

OPTIONAL



Çift El Kumanda Kontrolü ve Ayak Pedali
Two Hand Control and Foot Pedal



750mm ve 1000mm manuel arka dayama
Manual Back Gauge
750mm or 1000mm



İsteğe Bağlı Özel Abkant Bıçağı ve Prizma
Specific Blade and Prism

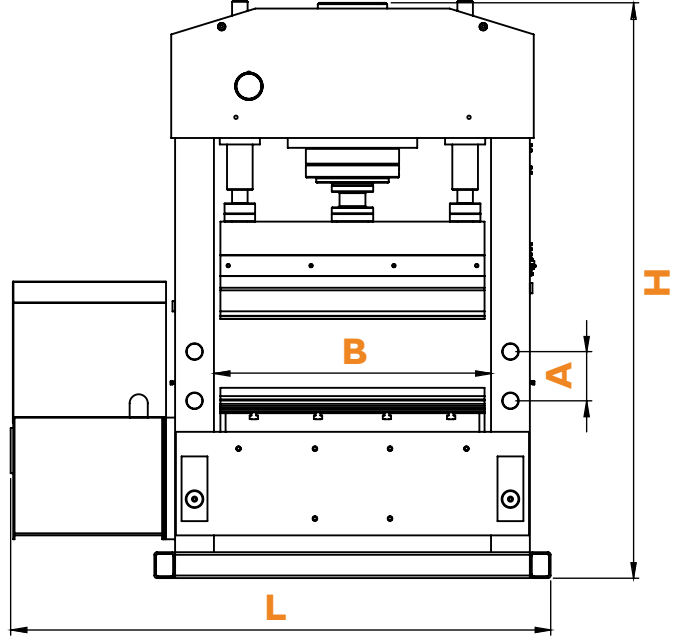
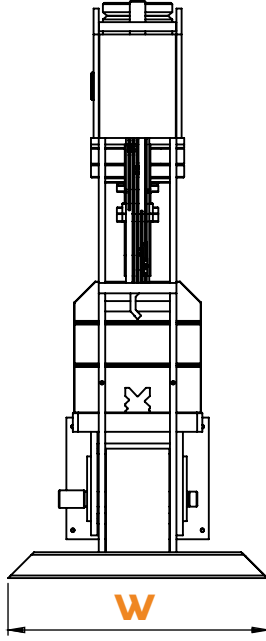

AP

			1020-100	1520-100	1020-150	1520-150
Basma Gücü	Press Power	kN	1000	1000	1500	1500
Maks. Çalışma Basıncı	Max. Working Pressure	bar	263	263	244	244
Kurs	Stroke	mm	300	300	300	300
Kıvrıma Kapasitesi	Bending Capacity	mm	6	6	10	10
İniş Hızı	Advance Speed	mm/sec	9	9	9	9
İş Hızı	Working Speed	mm/sec	5	5	5	5
Geri Dönüş Hızı	Return Speed	mm/sec	10	10	10	10
Tabla Ölçüsü	Table Dimension	mm	500x1020	500x1520	600x1020	600x1520
Alt Tabla Merkez Deliği	Bottom Table Hole Diameter	mm	100	100	100	100
Motor Gücü	Motor Power	kW	7,5	7,5	11	11
A Delik Mesafesi	A Hole Distance	mm	190	190	190	190
B Çalışma Aralığı	B Working Area	mm	1020	1520	1020	1520
L Uzunluk	L Length	mm	2110	2610	2110	2610
W Genişlik	W Width	mm	1000	1000	1000	1000
H Yükseklik	H Height	mm	2270	2270	2420	2420
Ağırlık	Weight	kg	2080	2500	2400	3350



GEZER PİSTON MOTORLU (AĞIR TİP)
MOBILE PISTON MOTORIZED (HEAVY DUTY)

DK

1900/200 Ton
1570-150 Ton
1570-100 Ton



Kremiyerli Gezer
Kafa Piston
Geared Moveable
Piston by
Hand Wheel

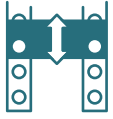

Ayarlanabilir
Alt Tabla
Adjustable
Bottom Table



Manometre
Manometer



Kumanda Kolu ile
Kontrol
Joystick Control



Yağ Tankı
Oil Tank

GENEL ÖZELLİKLER

- Kolay kullanım imkanı
- Çelik konstrüksiyon kaynaklı gövde
- İstenilen noktada durdurma imkanı
- Basınç göstergesi (manometre)
- Aşırı yüklemelere karşı emniyet ventili
- Kumanda kolu ile kontrol
- Ayarlanabilir alt tablalar
- Tabla indirme-kaldırma tertibatı
- Takım olarak işlenmiş V-yatakları
- Kremiyerli gezer piston
- Özel çift hız kumanda kolu ile kontrol (DK 1570x100 ve DK 1570x150)

GENERAL FEATURES

- Easy to operate
- Steel construction welded frame
- Ability to stop any position
- Manometer
- Relief valve for overloading
- Joystick control
- Adjustable bottom tables
- Table up-down movement attachment
- A pair of V-blocks
- Geared moveable piston by hand wheel
- Dual speed joystick control (DK 1570x100 and DK 1570x150)

OPSİYONEL

OPTIONAL



EL Pompası
(100 TON için geçerlidir)
Hand Pump
(Valid for 100 TON)



Ayak Pedalı
Foot Pedal



Dijital Kurs Göstergesi
Digital Stroke Read out



Limit Switch
Limit Switch

DK

1570-150



V-Yatağı
V-Blocks

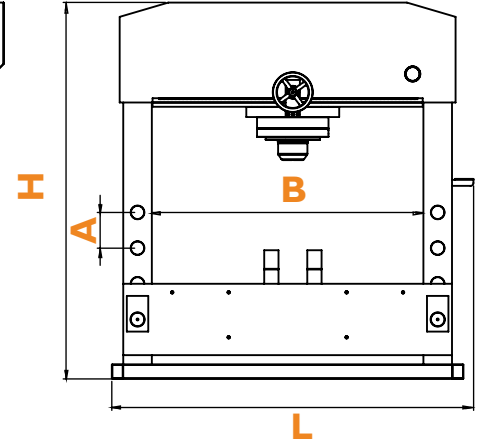
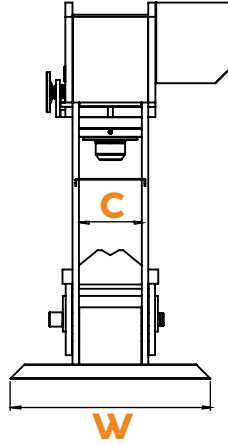

DK

			1570-100	1570-150	1900-200
Basma Gücü	Press Power	kN	1000	1500	2000
Maks. Çalışma Basıncı	Max. Working Pressure	bar	263	244	283
Kurs	Stroke	mm	300	300	300
Piston Kol Çapı	Diameter of Piston Arm	Ømm	220x160	280x200	300x210
İniş Hızı	Advance Speed	mm/sec	8	9	-
İş Hızı	Working Speed	mm/sec	5	5	6,5
Geri Dönüş Hızı	Return Speed	mm/sec	10	10	20
Motor Gücü	Motor Power	kW	5,5	11	15
A Delik Mesafesi	A Hole Distance	mm	190	190	250
B Çalışma Aralığı	B Working Area	mm	1570	1570	1900
C Derinlik	C Depth	mm	315	360	440
L Uzunluk	L Length	mm	2610	2610	2650
W Genişlik	W Width	mm	1000	1000	1665
H Yükseklik	H Height	mm	2625	2625	2860
Ağırlık	Weight	kg	1790	2400	4800



GEZER PİSTON MOTORLU
MOBILE PISTON MOTORIZED

DPM-K

1070/1570-150 Ton
1070/1570-100 Ton
1040-80 Ton
1040-60 Ton
775 - 30 Ton



Manometre
Manometer



**Rulman Hareketli
Gezer Piston**
Ball Bearing Mobile
Piston

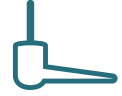

**Piston Hareket Kilit
Mekanizması**
Piston Movement
Lock System



V-Yatağı
V-Blocks



**Özel Çift Hız
Kumanda Kolu**
Dual Speed Joystick

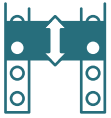

**Ayarlanabilir
Alt Tabla**
Adjustable
Bottom Table



GENEL ÖZELLİKLER

- Kolay kullanım imkanı
- Çelik konstrüksiyon kaynaklı gövde
- İstenilen noktada durdurma imkanı
- Basınç göstergesi (manometre)
- Aşırı yüklemelere karşı emniyet ventili
- Özel çift hız kumanda kolu ile kontrol
- Ayarlanabilir alt tablalar
- Tabla indirme-kaldırma tertibatı
- Takım olarak işlenmiş V-yatakları
- Rulman hareketli gezer piston

GENERAL FEATURES

- Easy to operate
- Steel construction welded frame
- Ability to stop any position
- Manometer
- Relief valve for overloading
- Dual speed joystick control
- Adjustable bottom tables
- Table up-down movement attachment
- A pair of V-blocks
- Ball bearing mobile piston

OPSİYONEL

OPTIONAL



El Pompası
(150 TON Hariç)
Hand Pump
(Except 150 TON)



Ayak Pedalı
Foot Pedal



Dijital Kurs Göstergesi
Digital Stroke Read out



Limit Switch
Limit Switch

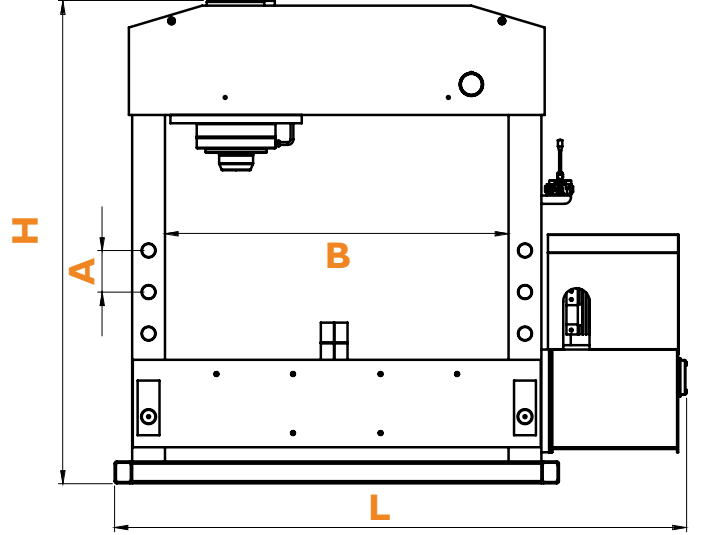
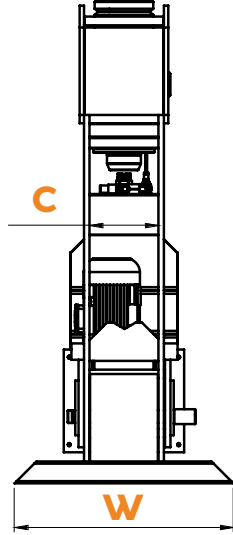

DPM-K

			775-30	1040-60	1040-80	1070-100	1570-100	1070-150	1570-150
Basma Gücü	Press Power	kN	300	600	800	1000	1000	1500	1500
Maks. Çalışma Basıncı	Max. Working Pressure	bar	244	236	255	263	263	244	244
Kurs	Stroke	mm	200	250	250	300	300	300	300
Piston Kol Çapı	Diameter of Piston Arm	Ømm	125x80	180x120	200x120	220x160	220x160	280x200	280x200
İniş Hızı	Advance Speed	mm/sec	7,5	8	8	8	8	9	9
İş Hızı	Working Speed	mm/sec	5	4	5	5	5	5	5
Geri Dönüş Hızı	Return Speed	mm/sec	10	10	10	10	10	10	10
Motor Gücü	Motor Power	kW	3	4	4	5,5	5,5	11	11
A Delik Mesafesi	A Hole Distance	mm	165	165	165	190	190	190	190
B Çalışma Aralığı	B Working Area	mm	775	1040	1040	1070	1570	1070	1570
C Derinlik	C Depth	mm	190	260	260	315	315	360	360
L Uzunluk	L Length	mm	1500	1810	1810	2110	2610	2110	2610
W Genişlik	W Width	mm	700	700	700	1000	1000	1000	1000
H Yükseklik	H Height	mm	2020	2100	2100	2430	2430	2480	2480
Ağırlık	Weight	kg	400	800	835	1500	1685	1870	2300



SABİT PİSTON MOTORLU
FIXED PISTON MOTORIZED

DPM

1070/1570-200 Ton



Manometre
Manometer



V-Yatağı
V-Blocks



Kumanda Kolu ile Kontrol
Joystick Control

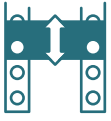

Ayarlanabilir
Alt Tabla
Adjustable
Bottom Table

GENEL ÖZELLİKLER

- Kolay kullanım imkanı
- Çelik konstrüksiyon kaynaklı gövde
- İstenilen noktada durdurma imkanı
- Basınç göstergesi (manometre)
- Aşırı yüklemelere karşı emniyet ventili
- Kumanda kolu ile kontrol
- Ayarlanabilir alt tablalar
- Tabla indirme-kaldırma tertibatı
- Takım olarak işlenmiş V-yatakları

GENERAL FEATURES

- Easy to operate
- Steel construction welded frame
- Ability to stop any position
- Manometer
- Relief valve for overloading
- Joystick control
- Adjustable bottom tables
- Table up-down movement attachment
- A pair of V-blocks

OPSİYONEL

OPTIONAL



Ayak Pedalı
Foot Pedal



Dijital Kurs Göstergesi
Digital Stroke Read out



Limit Switch
Limit Switch

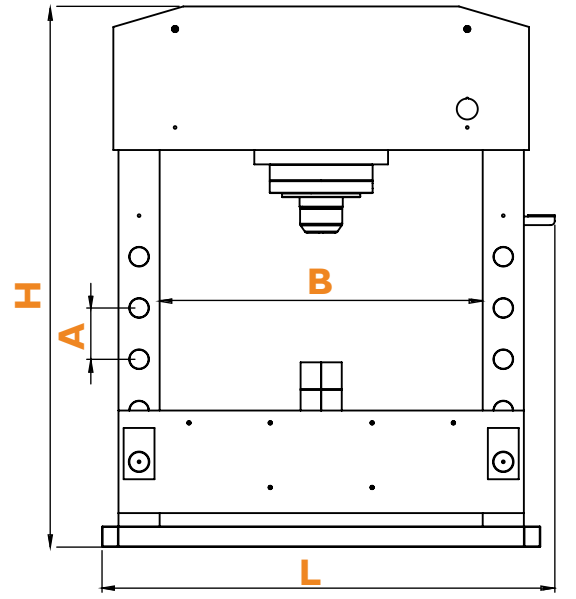
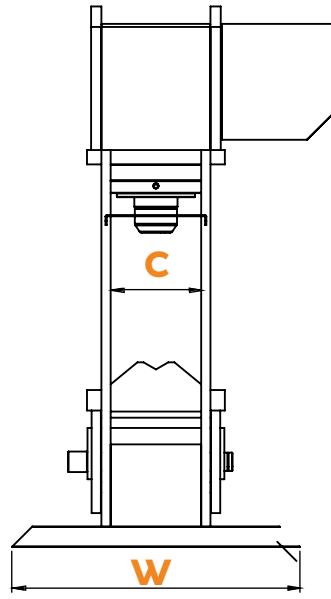

DPM

1070-200

1570-200

			1070-200	1570-200
Basma Gücü	Press Power	kN	2000	2000
Maks. Çalışma Basıncı	Max. Working Pressure	bar	283	283
Kurs	Stroke	mm	300	300
Piston Kol Çapı	Diameter of Piston Arm	Ømm	300x210	300x210
İş Hızı	Working Speed	mm/sec	6,5	6,5
Geri Dönüş Hızı	Return Speed	mm/sec	20	20
Motor Gücü	Motor Power	kW	15	15
A Delik Mesafesi	A Hole Distance	mm	250	250
B Çalışma Aralığı	B Working Area	mm	1070	1570
C Derinlik	C Depth	mm	440	440
L Uzunluk	L Length	mm	1800	2300
W Genişlik	W Width	mm	1660	1660
H Yükseklik	H Height	mm	2860	2860
Ağırlık	Weight	kg	4050	4500



SABİT PİSTON MOTORLU
FIXED PISTON MOTORIZED

DPM

1070/1570-150 Ton
1070/1570-100 Ton
1040-80 Ton
1040-60 Ton
775 - 30 Ton



Manometre
Manometer



V-Yatağı
V-Blocks



Özel Çift Hız
Kumanda Kolu
Dual Speed Joystick

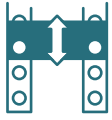

Ayarlanabilir
Alt Tabla
Adjustable
Bottom Table



GENEL ÖZELLİKLER

- Kolay kullanım imkanı
- Çelik konstrüksiyon kaynaklı gövde
- İstenilen noktada durdurma imkanı
- Basınç göstergesi (manometre)
- Aşırı yüklemelere karşı emniyet ventili
- Özel çift hız kumanda kolu ile kontrol
- Ayarlanabilir alt tablalar
- Tabla indirme-kaldırma tertibatı
- Takım olarak işlenmiş V-yatakları

GENERAL FEATURES

- Easy to operate
- Steel construction welded frame
- Ability to stop any position
- Manometer
- Relief valve for overloading
- Dual speed joystick control
- Adjustable bottom tables
- Table up-down movement attachment
- A pair of V-blocks

OPSİYONEL

OPTIONAL



**El Pompası
(150 TON Hariç)**
Hand Pump
(Except 150 TON)



Ayak Pedalı
Foot Pedal



Dijital Kurs Göstergesi
Digital Stroke Read out



Limit Switch
Limit Switch

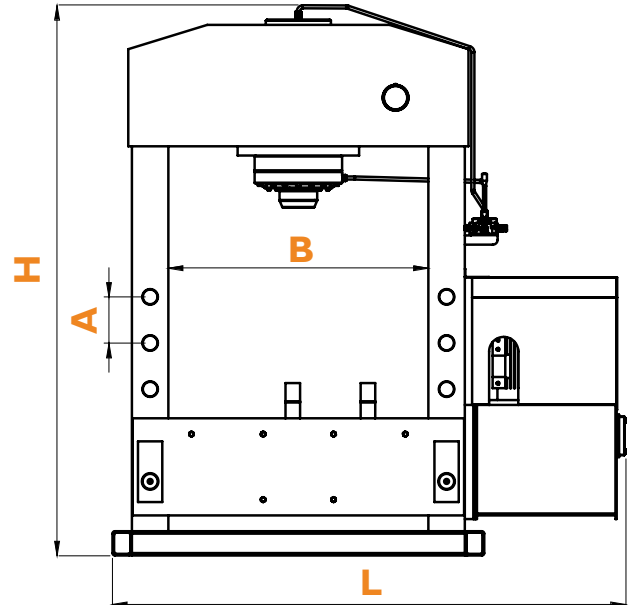
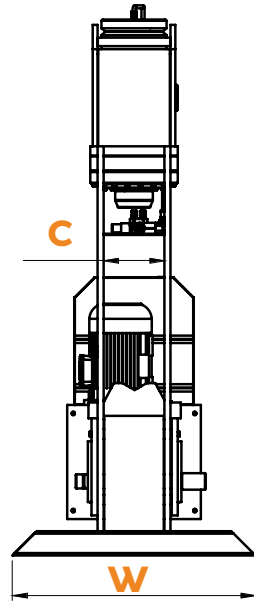

DPM

			775-30	1040-60	1040-80	1070-100	1570-100	1070-150	1570-150
Basma Gücü	Press Power	kN	300	600	800	1000	1000	1500	1500
Maks. Çalışma Basıncı	Max. Working Pressure	bar	244	236	255	263	263	244	244
Kurs	Stroke	mm	200	250	250	300	300	300	300
Piston Kol Çapı	Diameter of Piston Arm	Ømm	125x80	180x120	200x120	220x160	220x160	280x200	280x200
İniş Hızı	Advance Speed	mm/sec	7,5	8	8	8	8	9	9
İş Hızı	Working Speed	mm/sec	5	4	5	5	5	5	5
Geri Dönüş Hızı	Return Speed	mm/sec	10	10	10	10	10	10	10
Motor Gücü	Motor Power	kW	3	4	4	5,5	5,5	11	11
A Delik Mesafesi	A Hole Distance	mm	165	165	165	190	190	190	190
B Çalışma Aralığı	B Working Area	mm	775	1040	1040	1070	1570	1070	1570
C Derinlik	C Depth	mm	190	260	260	250	250	290	290
L Uzunluk	L Length	mm	1500	1800	1800	2110	2610	2110	2610
W Genişlik	W Width	mm	700	700	750	1000	1000	1000	1000
H Yükseklik	H Height	mm	2020	2100	2100	2290	2290	2340	2340
Ağırlık	Weight	kg	420	800	835	1420	1580	2200	2100



MANUEL KOLLU
MANUAL ARM

DP

600-30 Ton
500-20 Ton
500-10 Ton



Manometre
Manometer



V-Yatağı
V-Blocks

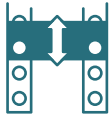

Ayarlanabilir
Alt Tabla
Adjustable
Bottom Table



Ayarlanabilir Piston Başı
Adjustable Piston Crown

DP

500-20

GENEL ÖZELLİKLER

- Kolay kullanım imkanı
- Çelik konstrüksiyon kaynaklı gövde
- İstenilen noktada durdurma imkanı
- Basınç göstergesi (manometre)
- Ayarlanabilir alt tablalar
- Takım olarak işlenmiş V-yatakları

GENERAL FEATURES

- Easy to operate
- Steel construction welded frame
- Ability to stop any position
- Manometer
- Adjustable bottom tables
- A pair of V-blocks

DP
500-10
MASA TİPİ
TABLE TYPE

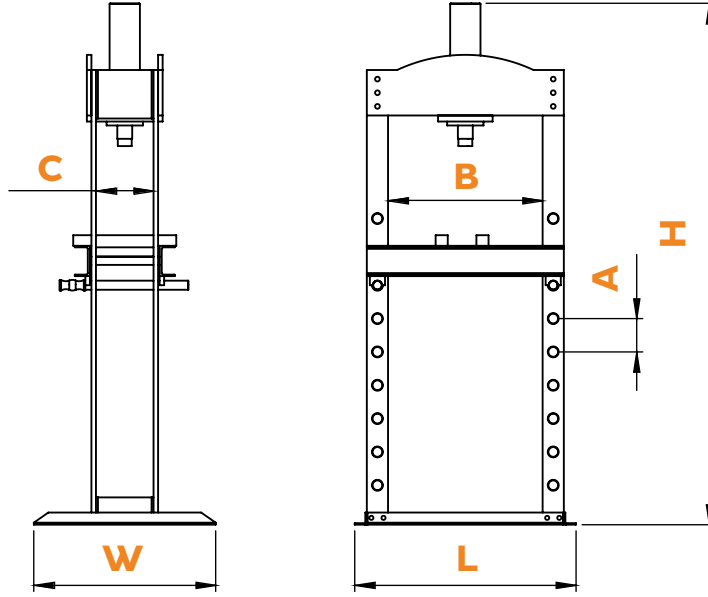

DP

			500-10	500-20	600-30
Basma Gücü	Press Power	kN	100	200	300
Maks. Çalışma Basıncı	Max. Working Pressure	bar	244	244	244
Kurs	Stroke	mm	125	125	125
Piston Kol Çapı	Diameter of Piston Arm	Ømm	80	85	90
A Delik Mesafesi	A Hole Distance	mm	200	200	200
B Çalışma Aralığı	B Working Area	mm	400	400	550
C Derinlik	C Depth	mm	190	190	190
L Uzunluk	L Length	mm	610	610	750
W Genişlik	W Width	mm	500	750	650
H Yükseklik	H Height	mm	1325	1570	1790
Ağırlık	Weight	kg	100	110	160



GİYOTİN MAKAS
GUILLOTINE SHEAR

Web Sitesine Git
Go To The Web Site



LRGM - 4 mm : 30

LRGM - 2-3 mm : 32



REDÜKTÖRLÜ GİYOTİN MAKAS
MECHANICAL GUILLOTINE SHEAR

LRGM

2050 / 2550 / 3050 - 4 mm



Parmak Koruma Bariyeri
Finger Protection



Tabaka Saclar İçin Ön Destek Kolları
Front Support Arms



Bilyalı Ön Tabla
Ball-bearing Front Table



Bıçak Sentil Ayarı
Blade Gap Adjustment



BRL NC Kontrol
BRL NC Control



Ayak Pedalı İle Kontrol
Foot Pedal Control

GENEL ÖZELLİKLER

- Çelik konstrüksiyon, kaynaklı gövde
- İki yüzü kullanılabilen sertleştirilmiş bıçaklar
- NC kontrollü 750mm arka dayama
- Kesim anında sacın kaymasını önleyen sac baskı sistemi
- Uzun saclar için ön destek dayama kolları (cetvel)
- Parmak koruma bariyeri
- Kesim hattı LED aydınlatması
- Ayak pedalı ile kontrol

GENERAL FEATURES

- Steel construction welded frame
- Two sided hardened blades
- Motorized 750mm NC back gauge
- Hold down system avoiding sheet sliding during operation
- Front support arms for long sheet cutting with ruler
- Finger protection
- Led lighting on cutting line
- Foot pedal control

OPSİYONEL

OPTIONAL

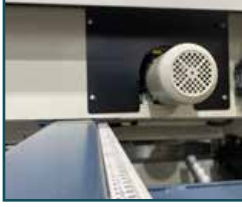

**NC Kontrollü, Motorlu
1000mm Arka Dayama**
Motorized 1000 mm
NC Back Gauge



Işık Koruma Bariyeri
Light Curtain



0-180° Ayarlanabilir Gönye
0-180° Angular Cutting



**Pnömatik Sac Destek
Sistemi**
Pneumatic Sheet Support

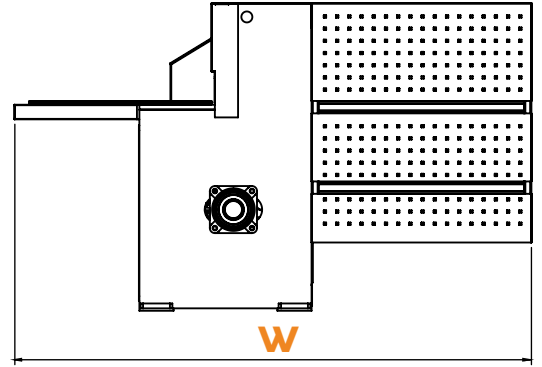
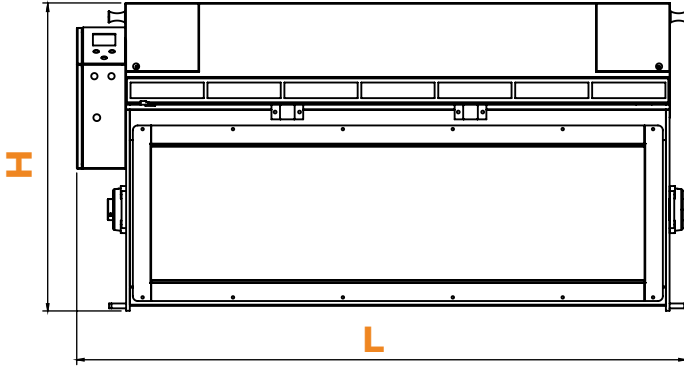

LRGM

			2050 - 4	2550 - 4	3050 - 4
Kesme Kapasitesi	Cutting Capacity	mm	4	4	4
Kesme Boyu	Cutting Length	mm	2050	2550	3050
Vuruş Sayısı	Stroke Per Minute	-	41	41	41
Tabla Genişliği	Table Width	mm	455	455	455
Arka Dayama Uzunluğu	Back Gauge Length	mm	750	750	750
Arka Dayama Motor Gücü	Back Gauge Motor Power	kW	0,55	0,55	0,55
Motor Gücü	Motor Power	kW	7,5	7,5	11
L Uzunluk	L Length	mm	2750	3250	3750
W Genişlik	W Width	mm	2250	2250	2250
H Yükseklik	H Height	mm	1450	1450	1450
Ağırlık	Weight	kg	3010	3510	3930



**REDÜKTÖRLÜ GİYOTİN MAKAS
MECHANICAL GUILLOTINE SHEAR**

LRGM

1350 / 1550 / 2050 - 3 mm
2550 / 3050 - 2 mm



Arka Dayama Mesafe Sayacı
Back Gauge Length Counter



Parmak Koruma Bariyeri
Finger Protection



Bilyalı Ön Tabla
Ball-bearing Front Table



Sayıcı
Counter



Ayak Pedalı İle Kontrol
Foot Pedal Control



Tabaka Saclar İçin Ön Destek Kolları
Front Support Arms

GENEL ÖZELLİKLER

- Çelik konstrüksiyon, kaynaklı gövde
- İki yüzü kullanılabilen sertleştirilmiş bıçaklar
- Manuel 750mm arka dayama
- Kesim anında sacın kaymasını önleyen sac baskı sistemi
- Uzun saclar için ön destek dayama kolları (cetvel)
- Parmak koruma bariyeri
- Kesim hattı LED aydınlatması
- Ayak pedalı ile kontrol

GENERAL FEATURES

- Steel construction welded frame
- Two sided hardened blades
- Manual 750mm back gauge
- Hold down system avoiding sheet sliding during operation
- Front support arms for long sheet cutting with ruler
- Finger protection
- Led lighting on cutting line
- Foot pedal control

OPSİYONEL

OPTIONAL



0-180° Ayarlanabilir Gönye
0-180° Angular Cutting



Işık Koruma Bariyeri
Light Curtain



Pnömatik Sac Destek Sistemi
Pneumatic Sheet Support

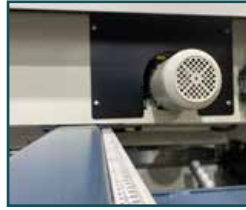

NC Kontrollü, Motorlu 1000mm Arka Dayama
Motorized 1000 mm NC Back Gauge



BRL NC Kontrol
BRL NC Control

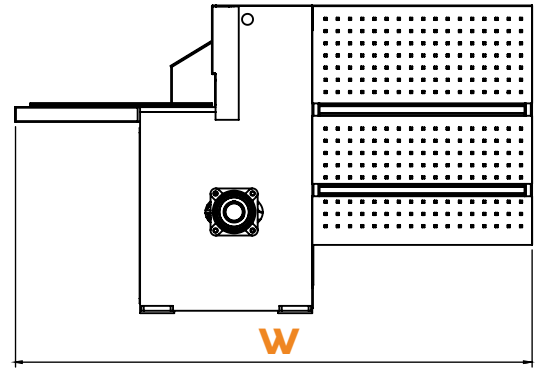
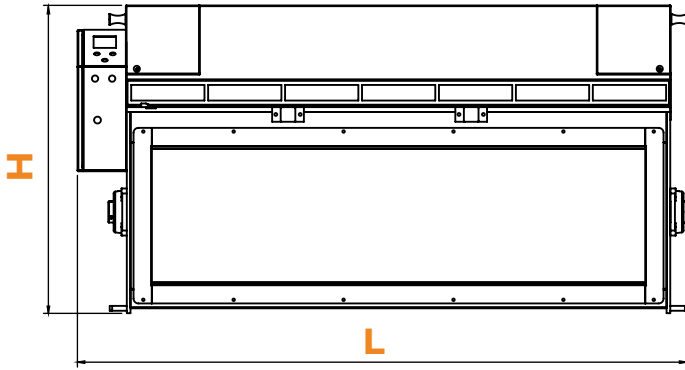

LRGM

			1350 - 3	1550 - 3	2050 - 3	2550 - 2	3050 - 2
Kesme Kapasitesi	Cutting Capacity	mm	3	3	3	2	2
Kesme Boyu	Cutting Length	mm	1350	1550	2050	2550	3050
Vuruş Sayısı	Stroke Per Minute	-	35	35	35	35	35
Tabla Genişliği	Table Width	mm	390	390	390	390	390
Arka Dayama Uzunluğu	Back Gauge Length	mm	750	750	750	750	750
Arka Dayama Motor Gücü (NC)	Back Gauge Motor Power (NC)	kW	0,55	0,55	0,55	0,55	0,55
Motor Gücü	Motor Power	kW	3	3	4	4	4
L Uzunluk	L Length	mm	1930	2130	2630	3160	3700
W Genişlik	W Width	mm	2310	2310	2310	2310	2250
H Yükseklik	H Height	mm	1250	1250	1250	1250	1310
Ağırlık	Weight	kg	1400	1500	1790	2000	2210



KÖŞE KESME
CORNER NOTCHER

Web Sitesine Git
Go To The Web Site



HNM 6 V	: 36
HNM 6F - 4F	: 38
P-FPN	: 40
MN	: 41



HİDROLİK AÇI AYARLI KÖŞE KESME
HYDRAULIC VARIABLE ANGLE
CORNER NOTCHER

HNM 6 V



Açı Ayarlı Gönye
Angular Cutting



Açı Ayarlı Bıçaklar
Angle Adjustable Blades



Elektrik Panosu
Electric Panel



GENEL ÖZELLİKLER

- HNM-6 V açı ayarlı hidrolik köşe kesme makinesi statik ve dinamik rijitliği sağlanmış çelik tabla ve üst çene malzemesi ile güçlü bir yapıya sahiptir.
- Hassas şekilde kesim yapabilmek için makinenin üst tablası T-kanallı olarak işlenmiştir ve farklı sac kalınlıklarını kesmek için ayrı ayar gerektirmeyen otomatik sentil ayar sistemi ile donatılmıştır.
- 4 hidrolik baskı silindiri sayesinde sık tekrarlanabilir kesim imkanı sunmaktadır.
- Maksimum 6 mm kalınlık kesme kapasitesi
- Ayak pedali ile kontrol

GENERAL FEATURES

- HNM-6 V variable rake hydraulic corner notchers have a strong frame with its statically and dynamically rigid steel table and top beam material.
- T slot top table realizes precise cuttings and there is no need for alignment for different sheet thicknesses by means of automatic blade gap adjustment.
- HNM-6 V series perform frequent cutting repeatability via 4 hydraulic hold-down cylinders.
- Max. 6mm thickness cutting capacity.
- Foot pedal control

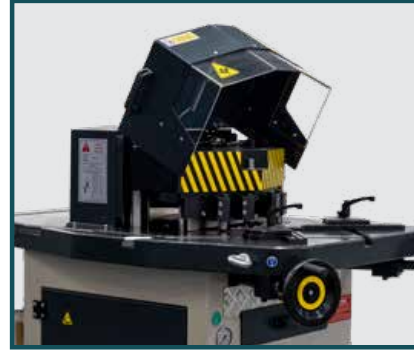
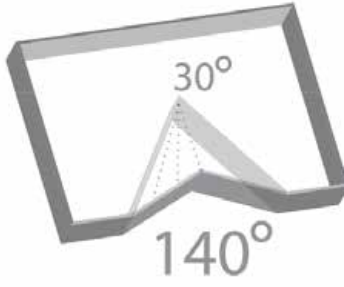
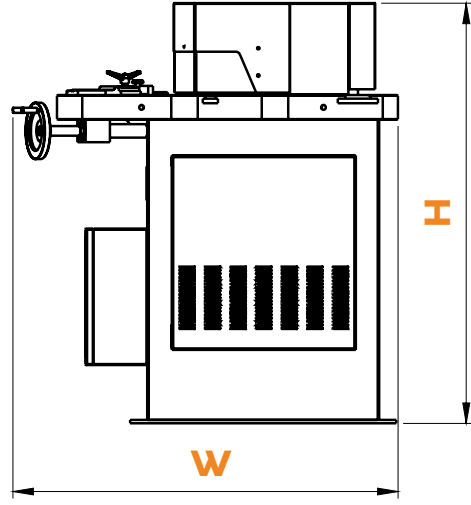
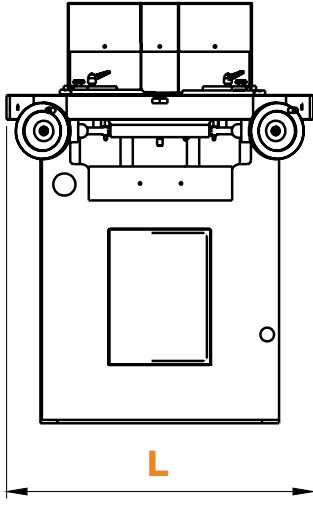

HNM

6 V

Çelik Kesme	Steel Cutting	mm 60..140°	6 - 4
Paslanmaz Kesme	Stainless Cutting	mm 60..140°	3 - 2
Motor Gücü	Power	kW	4
Tabla Boyutu	Table Dimension	mm	900x1000
Kesme Açısı	Cutting Angle	°	30x140 °
Maksimum Kesme / dk.	Max. Cutting Per Minute	x	30
Bıçak Boyu	Blade Length	mm	200x200
Yağ Tank Kapasitesi	Oil Tank Capacity	lt.	35
Maksimum Çalışma Basıncı	Max. Working Pressure	bar	200
L Uzunluk	L Length	mm	900
W Genişlik	W Width	mm	1150
H Yükseklik	H Height	mm	1240
Ağırlık	Weight	kg	1150



HİDROLİK SABİT AÇILI KÖŞE KESME
HYDRAULIC FIXED ANGLE
CORNER NOTCHER

HNM 6F - 4F



Açı Ayarlı Gönye
Angular Cutting



Sabit 90° Açılı Bıçaklar
Fixed 90° Blades



Elektrik Panosu
Electric Panel



GENEL ÖZELLİKLER

- Sabitlenmiş 90° sayesinde hızlı köşe çıkarma.
- Az hacmi sayesinde rahat bir çalışma imkanı sunar.
- Ayak pedali ile kontrol

GENERAL FEATURES

- The notching angle axes in 90° with high notching speed.
- The hydraulic notcher has compact structure, small volume and convenient operation.
- Foot pedal control

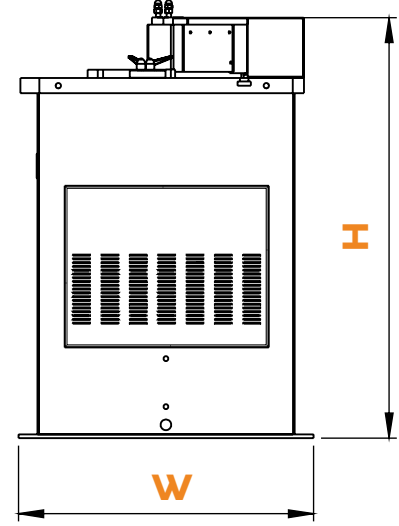
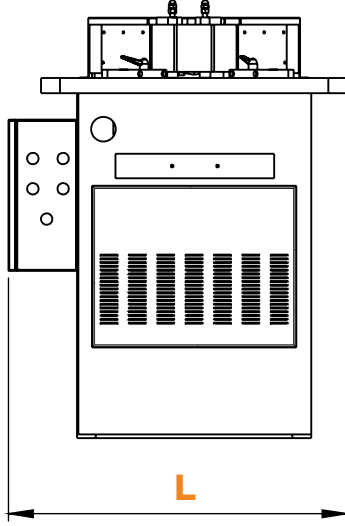

HNM

			6 F	4 F
Çelik Kesme	Steel Cutting	mm 90°	6	4
Paslanmaz Kesme	Stainless Cutting	mm 90°	3	2
Motor Gücü	Power	kW	4	4
Tabla Boyutu	Table Dimension	mm	810x750	700x690
Kesme Açısı	Cutting Angle	°	90	90
Maksimum Kesme / dk.	Max. Cutting Per Minute	x	25	20
Bıçak Boyu	Blade Length	mm	250x250	197x197
Yağ Tank Kapasitesi	Oil Tank Capacity	lt.	45	45
Maksimum Çalışma Basıncı	Max. Working Pressure	bar	200	120
L Uzunluk	L Length	mm	950	890
W Genişlik	W Width	mm	780	780
H Yükseklik	H Height	mm	1115	1115
Ağırlık	Weight	kg	585	550



PNÖMATİK AYAK PEDALLI
KÖŞE KESME
PNEUMATIC FOOT PEDAL
CORNER NOTCHER

P-FPN



GENEL ÖZELLİKLER

- Ayak Pedallı çalışma
- 90 derece sabit kesme açısı
- Ayarlanabilir çalışma alanı
- Ayarlanabilir Bıçak Boşlukları

GENERAL FEATURES

- Foot Pedal Operation
- 90 degree fixed angle cutting
- Adjustable Work Stops
- Adjustable Blades Gap



P-FPN

P-FPN		P-FPN	
Kesme Kapasitesi	Notching Capacity	mm	1,5
Bıçak Ölçüsü	Blade Size	mm	80x80
Koç Mesafesi	Stroke	mm	25
Derece	Angle	°	90
Uzunluk	Length	mm	550
Genişlik	Width	mm	400
Yükseklik	Height	mm	1200
Ağırlık	Weight	kg	130



KOLLU MANUEL KÖŞE KESME
ARM LEVER CORNER NOTCHER

MN-3 | MN-1,5



Döküm Gövde
Cast Frame



Platina Sac Kaynaklı Gövde
Plate Steel Welded Frame



Opsiyonel Stand
Optional Stand

GENEL ÖZELLİKLER

- Çelik sac, demir çubuk ve lama kesme için idealdir
- Kaliteli çelik alaşımlı dayanıklı bıçak
- Rahatça taşınabilir ve Tezgah üstüne monte edilebilir
- Kolay bıçak değişimi

GENERAL FEATURES

- Ideal for Steel plate , rod steel and flat bar cutting
- High tensile durable blades
- Easy to carry and Mount on a table or stand
- Easy blade exchangable



MN

			MN 3	MN 1,5
Kesme Kapasitesi	Notching Capacity	mm	3	1,5
Kesme Ölçüsü	Cutting Dimensions	mm	100x100	152x152
Koç Mesafesi	Stroke	mm	30	20
Derece	Angle	°	90	90
Uzunluk	Length	mm	460	580
Genişlik	Width	mm	450	530
Yükseklik	Height	mm	760	520
Ağırlık	Weight	kg	105	80



PROFİL & BORU KIVIRMA
PROFILE & PIPE BENDING

Web Sitesine Git
Go To The Web Site



PK 35	: 44
PK 30	: 46
KAPASİTE TABLOSU CAPACITY CHART	: 48



PROFİL & BORU KIVIRMA
PROFILE & PIPE BENDING

PK 35

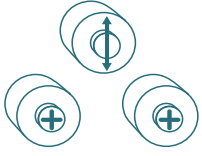

Tahrikli Alt Vals Topları
Two Bottom Powered Rolls



Yan Dayama Ayarı
Adjustable guide rolls



Ayak Pedalı ile Kontrol
Foot Pedal Control



Yatay Çalışma Pozisyonu
Horizontal Working Position

GENEL ÖZELLİKLER

- Çelik gövde
- 2 alt vals topu dişli sistemle direk tahrik edilmiştir
- Üst mil boşta hareket etmektedir
- Vals topları sertleştirilmiştir
- Vals milleri özel çelikten, sertleştirilmiş ve taşlanmıştır
- Standart vals topları
- Ayarlanabilir yan dayamalar
- Yatay ve dikey çalışma imkanı
- Ayak pedalı ile kontrol

GENERAL FEATURES

- Steel construction frame
- Two bottom rolls direct driven by gear system
- Top roll is idle
- Hardened rolls
- Rolls shafts are special hardened steel and ground
- Standard rolls
- Adjustable guide rolls
- Horizontal and vertical working position
- Foot pedal control

OPSİYONEL

OPTIONAL

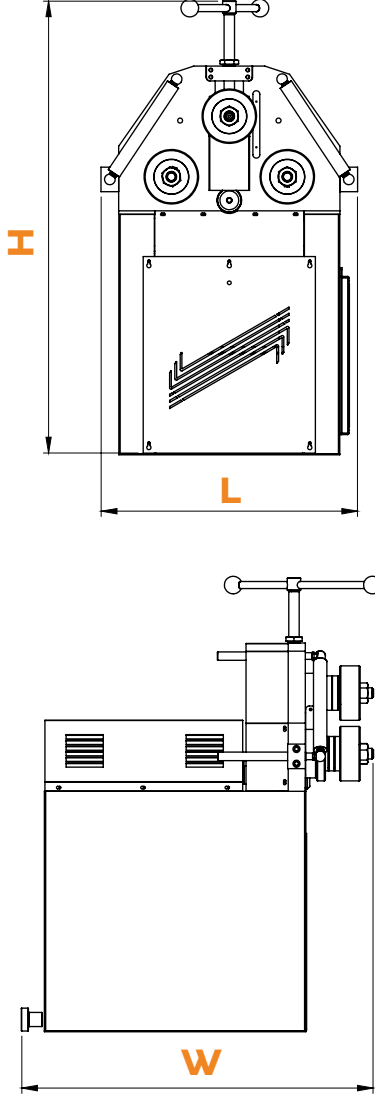

Boru Bükme Vals Topları
Pipe / Tube Bending Rolls



Köşebent Bükme Vals Topları ve Dayama Aparatı
Angle Bending Rolls and Lateral Guide Rolls



Dijital Gösterge
Digital Read out

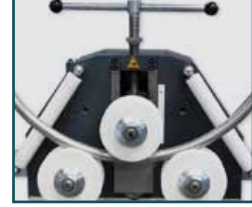

Paslanmaz Malzeme Kıvrımına Özel Delrin Vals Topları
Plastic Rolls For Stainless Steel Bending



Özel Burgu Aparatı
Special Bar Twist Attachment



Özel Salyangoz Bükme Aparatı
C&S forming attachment



PK

35

Mil Çapları	Roll Shafts	Ømm	50
Üst Vals Topu Çapı	Upper Roll Diameter	Ømm	155
Çalışma Hızı	Working Speed	m/min	4,5
Motor Gücü	Motor Power	kW	1,5
L Uzunluk	L Length	mm	750
W Genişlik	W Width	mm	1000
H Yükseklik	H Height	mm	1400
Ağırlık	Weight	kg	400



PROFİL & BORU KIVIRMA
PROFILE & PIPE BENDING

PK 30



Yatay Çalışma Pozisyonu
Horizontal Working Position



Yan Dayama Ayarı
Adjustable guide rolls

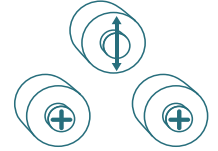

Tahrikli Alt Vals Topları
Two Bottom Powered Rolls



Ayak Pedalı ile Kontrol
Foot Pedal Control

GENEL ÖZELLİKLER

- Çelik gövde
- 2 alt vals topu dişli sistemle tahrik edilmiştir
- Redüktörden direkt dişli sistemi ile tahrik edilmiştir
- Üst mil boşta hareket etmektedir
- Vals topları sertleştirilmiştir
- Vals milleri özel çelikten, sertleştirilmiş ve taşlanmıştır
- Çift hızlı motor
- Standart vals topları
- Ayarlanabilir yan dayamalar
- Yatay ve dikey çalışma imkanı
- Ayak pedalı ile kontrol

GENERAL FEATURES

- Steel construction frame
- Two bottom rolls are powered
- Direct drive power system with gears
- Top roll is idle
- Hardened rolls
- Rolls shafts are special hardened steel and ground
- Double speed motor
- Standard rolls
- Adjustable guide rolls
- Horizontal and vertical working position
- Foot pedal control

OPSİYONEL

OPTIONAL

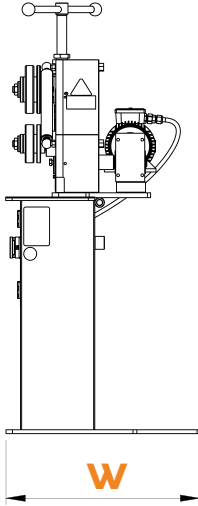
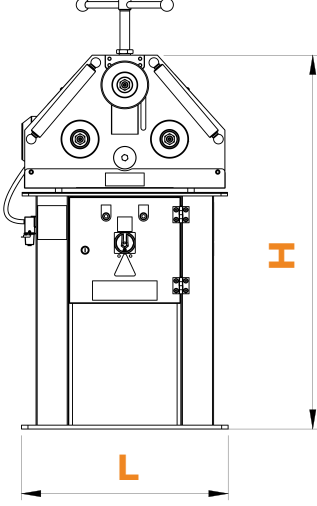

Boru Bükme Vals Topları
Pipe / Tube Bending Rolls



Köşebent Bükme Vals Topları ve Dayama Aparatı
Angle Bending Rolls and Lateral Guide Rolls



Dijital Gösterge
Digital Read out

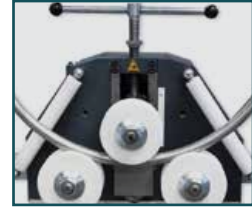

Paslanmaz Malzeme Kıvrımına Özel Delrin Vals Topları
Plastic Rolls For Stainless Steel Bending



Özel Burgu Aparatı
Special Bar Twist Attachment



Özel Salyangoz Bükme Aparatı
C&S forming attachment



PK

30

Mil Çapları	Roll Shafts	Ømm	30
Üst Vals Topu Çapı	Upper Roll Diameter	Ømm	148
Alt Vals Topu Çapı	Bottom Roll Diameter	Ømm	118
Çalışma Hızı	Working Speed	m/min	2-4
Motor Gücü	Motor Power	kW	0,7-0,85
L Uzunluk	L Length	mm	640
W Genişlik	W Width	mm	600
H Yükseklik	H Height	mm	1280
Ağırlık	Weight	kg	220



KIVIRMA KAPASİTELERİ CAPACITY CHART

NO	Profil cinsi Profile Type	PK 30		PK 35		Açıklama Notes
		Ölçüler Size	Kiv. Çapı Min Dia.	Ölçüler Size	Kiv. Çapı Min Dia..	
1		50x10 20x6	1800 300	60x10 40x10	500 400	Standart Valsler Standard Rolls
2		80x15 * 30x6 *	700 400	100x15 60x10	450 350	Standart Valsler Standard Rolls
3		30x30 10x10	900 200	35x35 20x20	900 300	Standart Valsler Standard Rolls
4		Ø 30 Ø 10	900 200	Ø 35 Ø 30	600 400	Özel Valsler Optional Rolls
5		Ø 60"x1,5 Ø 25x1,5	1000 600	Ø 70x2 Ø 30x2	1000 500	Özel Valsler Optional Rolls
6		1 1/2"x2,9 1/4"x1,8	600 300	2"x2,9 1"x2,3	1000 350	Özel Valsler Optional Rolls
7		50x30x3 40x20x2	1200 800	70x30x2 50x40x3	1200 1200	Özel Valsler Optional Rolls
8		40x3 30x2	1200 800	50x3 40x3	1700 600	Özel Valsler Optional Rolls
9		40x40x5 30x30x4	600 300	50x50x5 40x40x5	800 600	Özel Valsler Optional Rolls
10		35x35x5 30x30x4	600 400	50x50x6 30x30x3	1000 500	Özel Valsler Optional Rolls
11		50x6 20x3	600 400	60x7 30x4	700 400	Standart Valsler Standard Rolls
12		50x6 20x3	600 400	60x7 30x4	800 500	Standart Valsler Standard Rolls
13		50x6 20x3	600 400	60x7 30x4	700 500	Standart Valsler Standard Rolls
14				UPN 80 UPN 30	1000 500	Standart Valsler Standard Rolls
15				UPN 80 UPN 30	1200 800	Standart Valsler Standard Rolls

* Özel pul gerekebilir.

* Special washer may be required.

NOTES

A series of horizontal dotted lines for writing notes.

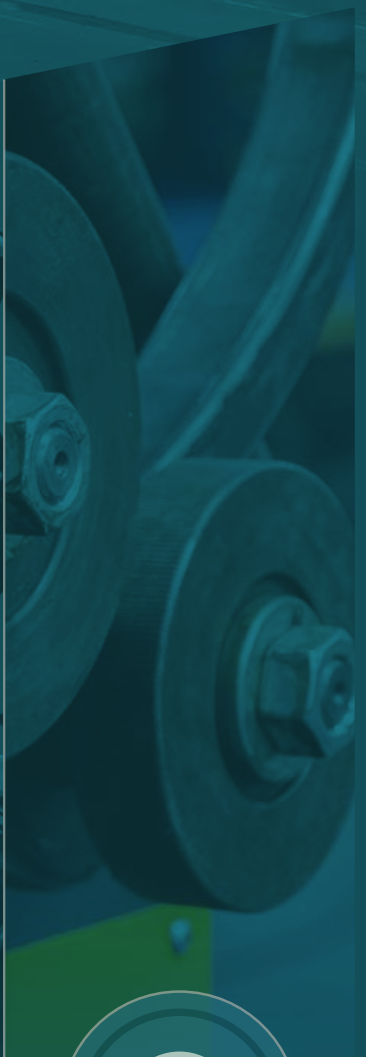

Vertrauen Sie auf bald 80 Jahre Erfahrung!

Die Firma **Hesse + Co** wurde 1947 als Hersteller von Blechbearbeitungsmaschinen gegründet. Seit 1980 sind wir auf den Handel mit neuen sowie gebrauchten Blechbearbeitungs- und Werkzeugmaschinen spezialisiert.

Wir haben ständig etwa 300 Maschinen in unserer 2.000 m² großen Ausstellungshalle, die nur 20 Minuten vom internationalen Flughafen Wien entfernt ist.

Trust in nearly 80 years of experience!

Hesse + Co was established in 1947 as a manufacturer of sheet metal working machines. Since 1980 we are specialized in dealing with new and second hand sheet metal processing machines and machine tools. We always have approximately 300 machines available in our 2.000 m² showroom, which is located only 20 minutes from the Vienna International Airport, waiting for your inspection.

www.hesse-maschinen.com

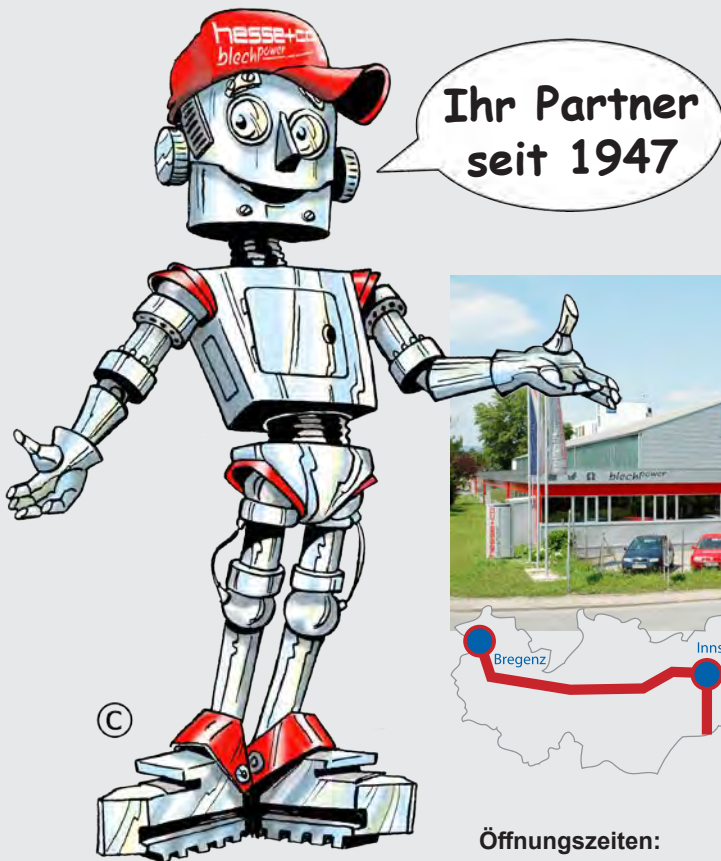

Öffnungszeiten:

Mo - Do 7:45 - 16:30 Uhr
Fr 7:45 - 13:15 Uhr

Hesse + Co Maschinenfabrik GmbH
Industriezentrum NÖ-Süd
Straße 4 - Objekt 8
A-2351 Wiener Neudorf
AUSTRIA

hesse **hesse+co**
blechpower
maschinen und werkzeuge

Tel.: +43/2236/638 70-0
office@hesse-maschinen.com
www.hesse-maschinen.com

Technische Änderungen, Irrtum und Druckfehler vorbehalten.
Gültig bis auf Widerruf.